

Current Transducer LTC 350-S

$I_{PN} = 350 \text{ A}$

For the electronic measurement of currents : DC, AC, pulsed..., with a galvanic isolation between the primary circuit (high power) and the secondary circuit (electronic circuit).



17018

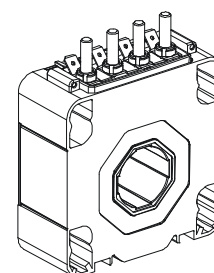

Electrical data

I_{PN}	Primary nominal r.m.s. current	350	A		
I_P	Primary current, measuring range @ 24 V	0 .. ± 1200	A		
R_M	Measuring resistance	R_{Mmin}	R_{Mmax}		
				with ± 15 V	@ ± 500 A _{max}
	with ± 24 V	@ ± 900 A _{max}	0	8	Ω
	with ± 24 V	@ ± 500 A _{max}	10	60	Ω
		@ ± 1200 A _{max}	10	17	Ω
I_{SN}	Secondary nominal r.m.s. current	175	mA		
K_N	Conversion ratio	1 : 2000			
V_C	Supply voltage (± 5 %)	± 15 .. 24	V		
I_C	Current consumption	< 35 (@±24V) + I_S	mA		

Features

- Closed loop (compensated) current transducer using the Hall effect
- Isolated plastic case recognized according to UL 94-V0.

Advantages

- Excellent accuracy
- Very good linearity
- Low temperature drift
- Optimized response time
- Wide frequency bandwidth
- No insertion losses
- High immunity to external interference
- Current overload capability.

Accuracy - Dynamic performance data

X_G	Overall accuracy @ I_{PN} , $T_A = 25^\circ\text{C}$	< ± 0.5	%
e_L	Linearity error	< 0.1	%
		Maxi	
I_O	Offset current @ $I_P = 0$, $T_A = 25^\circ\text{C}$	± 0.5	mA
I_{OT}	Thermal drift of I_O - 40°C .. + 85°C	± 0.8	mA
t_r	Response time ¹⁾ @ 90 % of I_{PN}	< 1	μs
di/dt	di/dt accurately followed	> 100	A/μs
f	Frequency bandwidth (- 1 dB)	DC .. 100	kHz

Applications

- Single or three phases inverter
- Propulsion and braking chopper
- Propulsion converter
- Auxiliary converter
- Battery charger.

General data

T_A	Ambient operating temperature	- 40 .. + 85	°C
T_S	Ambient storage temperature	- 45 .. + 90	°C
R_S	Secondary coil resistance @ $T_A = 85^\circ\text{C}$	15	Ω
m	Mass	400	g
	Standards	EN 50155: 2001	

Application Domain

- Traction

Note: ¹⁾ With a di/dt of 100 A/μs.

Current Transducer LTC 350-S

Isolation characteristics

V_d	R.m.s. voltage for AC isolation test, 50 Hz, 1 mn	12 ²⁾	kV
		1.5 ³⁾	kV
		Min	
dCp	Creepage distance	50	mm
dCl	Clearance distance	44	mm
CTI	Comparative Tracking Index (Group I)	600	

Notes : ²⁾ Between primary and secondary + shield

³⁾ Between secondary and shield.

Safety



This transducer must be used in electric/electronic equipment with respect to applicable standards and safety requirements in accordance with the following manufacturer's operating instructions.



Caution, risk of electrical shock

When operating the transducer, certain parts of the module can carry hazardous voltage (eg. primary busbar, power supply).

Ignoring this warning can lead to injury and/or cause serious damage.

This transducer is a built-in device, whose conducting parts must be inaccessible after installation.

A protective housing or additional shield could be used.

Main supply must be able to be disconnected.

Dimensions LTC 350-S (in mm. 1 mm = 0.0394 inch)

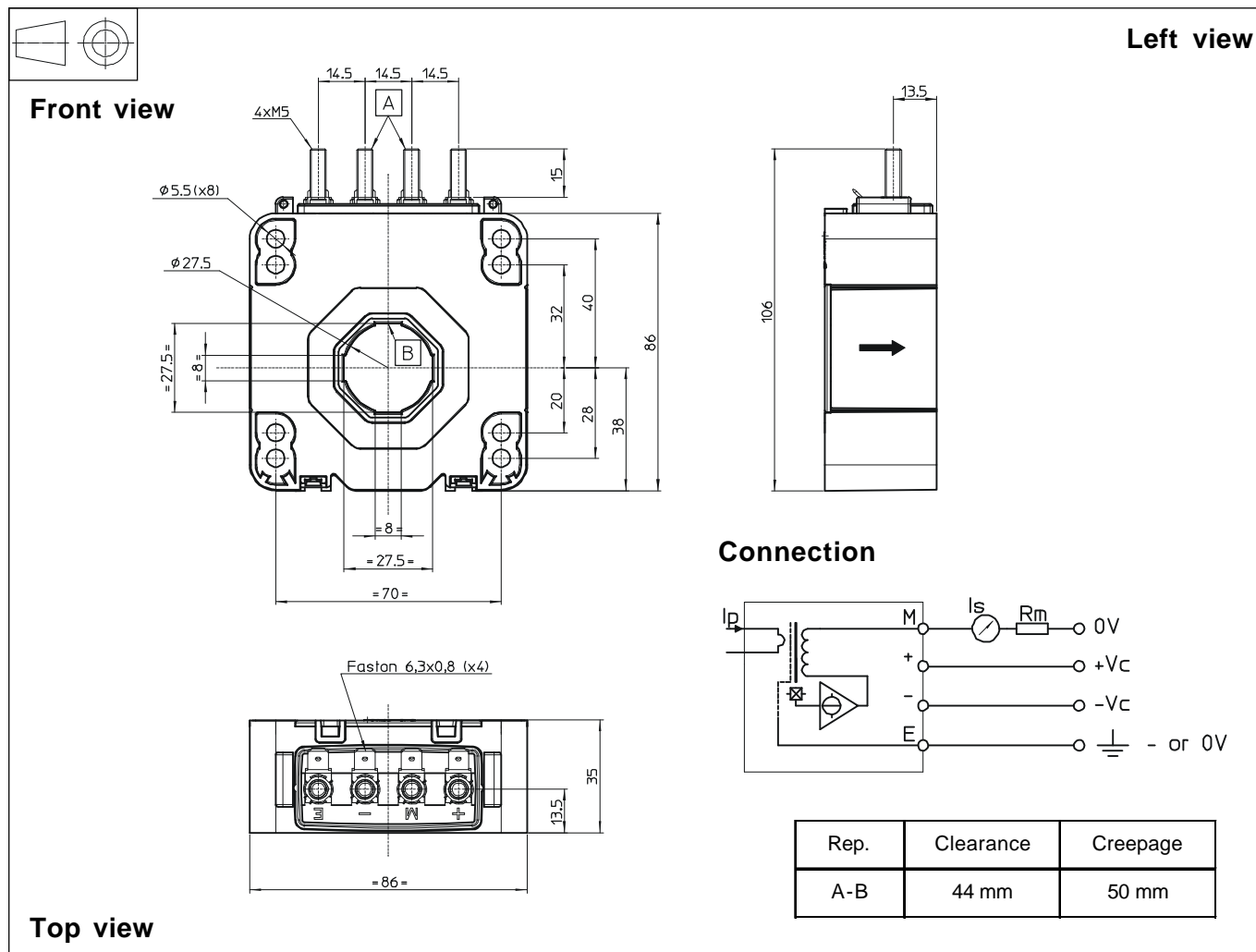

Mechanical characteristics

- General tolerance ± 1 mm
- Transducer fastening
 - 8 holes $\varnothing 5.5$ mm
 - 4 M5 steel screws
 - Recommended fastening torque 3.4 Nm or 2.51 Lb.-Ft.
- Primary through-hole $\varnothing 27.5$ mm
- Connection of secondary
 - 4 M5 threaded studs
 - Recommended fastening torque 2.2 Nm or 1.62 Lb.-Ft.
 - Faston 6.3 x 0.8 mm

Remarks

- I_s is positive when I_p flows in the direction of the arrow.
- Temperature of the primary conductor should not exceed 100°C.
- Dynamic performances (di/dt and response time) are best with a single bar completely filling the primary hole.
- This is a standard model. For different versions (supply voltages, turns ratios, unidirectional measurements...), please contact us.

LTC 350-S / Mechanical adaptation accessories

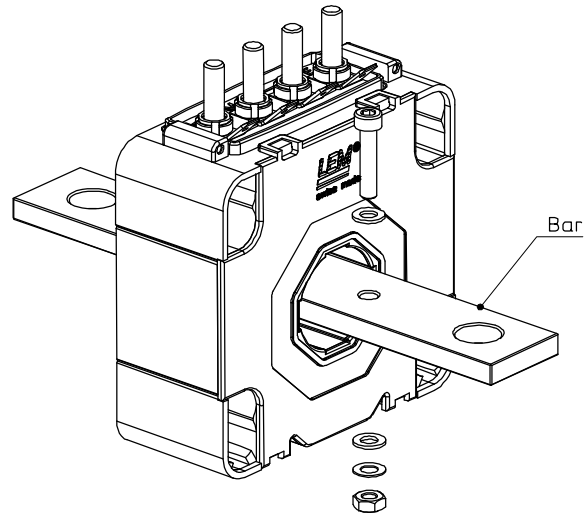
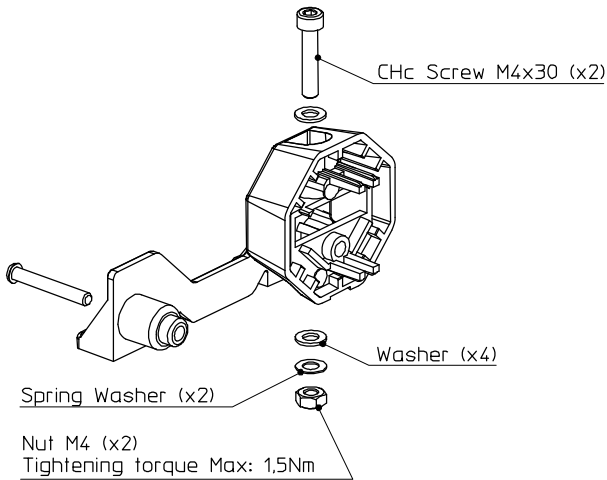

Other possibilities of assembly
of Feet, Bar and Clamps

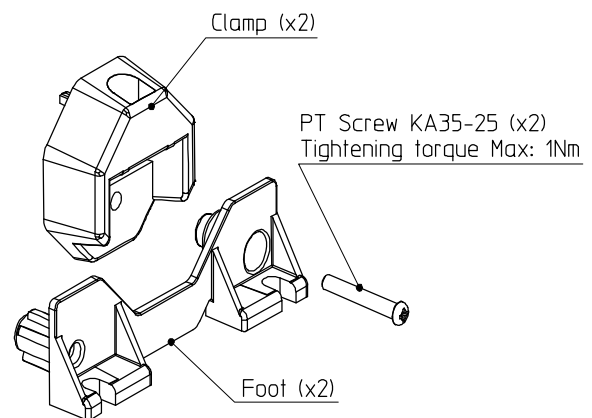
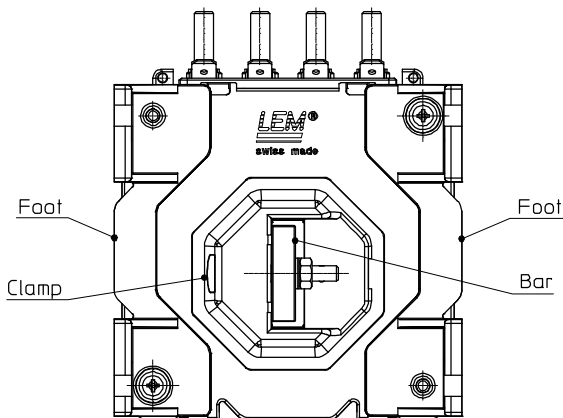

Accessories	References
Busbar Kit *(busbar : 155 x 25 x 6 mm)	93.34.41.100.0
Busbar Kit *(busbar : 112 x 25 x 6 mm)	93.34.41.101.0
Busbar fastening Kit **	93.34.41.200.0
Feet fixing Kit ***	93.34.43.100.0

- * including all the necessary for its mounting such as screws, washers, nuts, 2 clamps, busbar.
- ** as with * but without the busbar.
- *** including screws and 2 feet.



R.m.s. voltage value for partial discharge extinction depends on the busbar.
Refer to the datasheet of the corresponding product.